

**!WARNING!**

SPACE BETWEEN DOOR AND HOISTWAY  
MUST NOT EXCEED 3"

INTERLOCKS CONFORMING TO ASME A17.1  
MUST BE INSTALLED AND ADJUSTED PER  
THE MANUFACTURER'S INSTRUCTIONS.

**!FAILURE TO COMPLY  
MAY RESULT IN SERIOUS  
INJURY OR DEATH!**

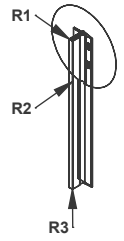
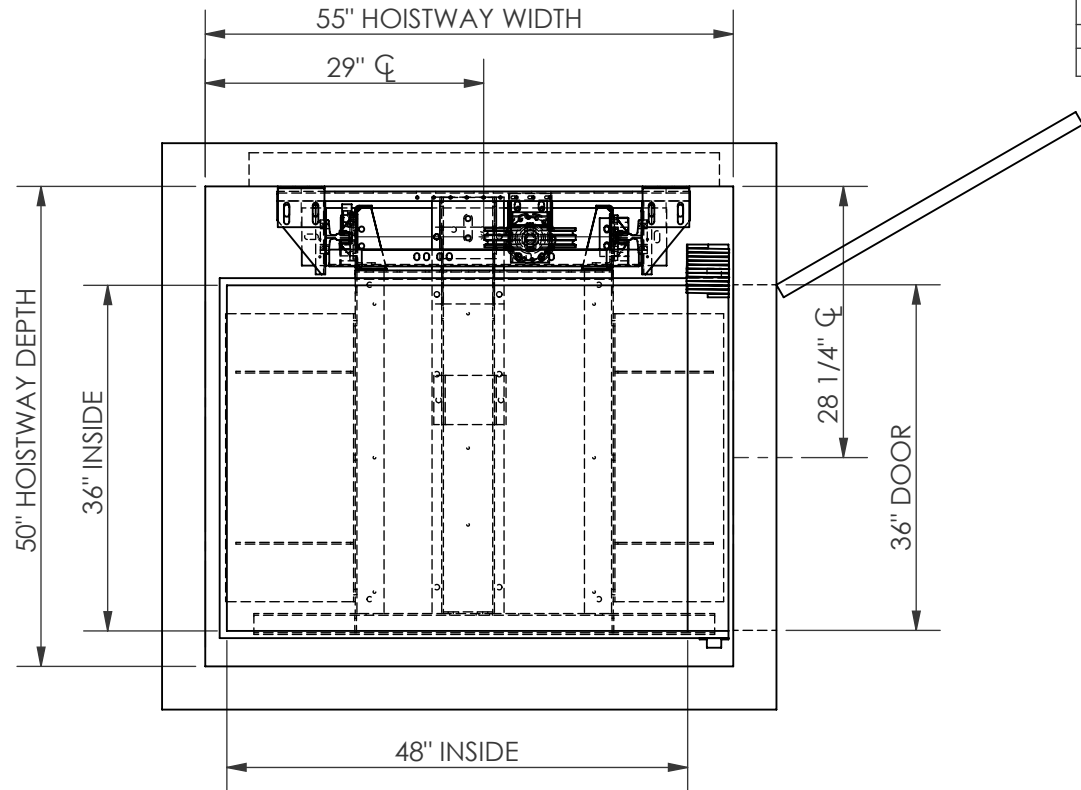
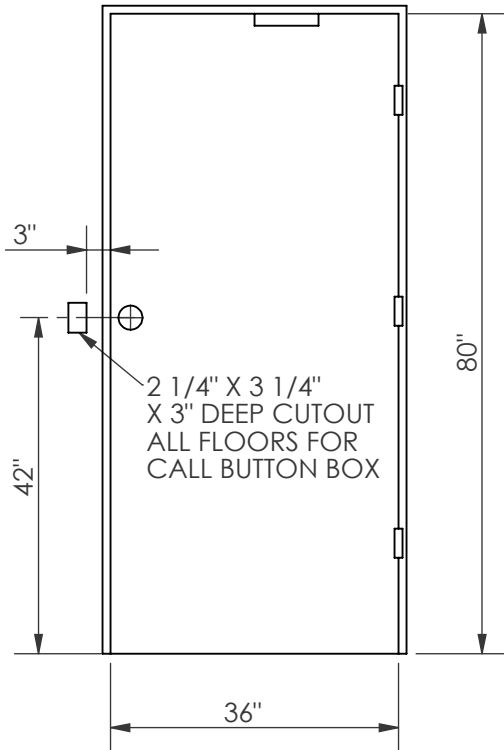
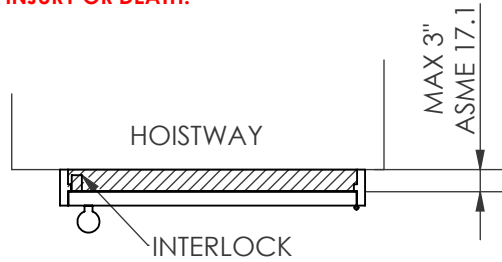

RAIL WEIGHT: 8 lbs/ft

RAIL FORCES

*R1(Fx)	1075 lbs
*R2(Fy)	358 lbs
R3(Fz)	2500 lbs

SIZE **A**  **Nationwide Lifts**  
America's *leader* in home elevators.

PART NO.  
**36 X 48, 1R**  
SHEET 1 OF 3  
DESCRIPTION:  
SWING DOORS, HYDRO

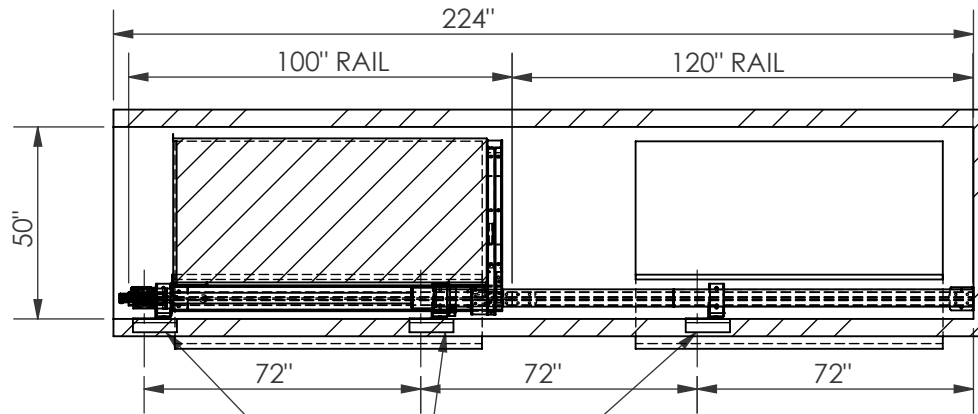

BRACKET LOCATIONS MAY VARY  
ACCORDING TO TRAVEL

PROVIDE WALL CONSTRUCTION  
SUITABLE FOR ATTACHMENT OF  
RAIL BRACKETS AT SHOWN ELEVATION.  
MUST BE CAPABLE OF 300LB PULLOUT  
LOADING WITH MAX DEFLECTION OF 1/8".

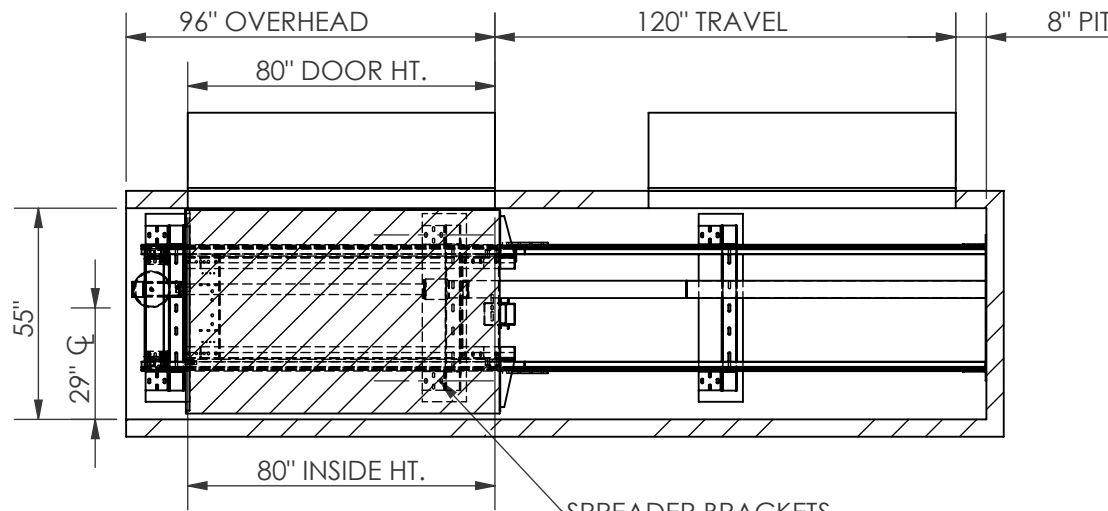

SPREADER BRACKETS  
FASTEN WITH LAG SCREWS  
2 PLACES PER SIDE BRACKET

SIZE <b>A</b>	 <i>America's leader in home elevators.</i>
------------------	---

PART NO.  
**36 X 48, 1R**  
SHEET 2 OF 3  
DESCRIPTION:  
SWING DOORS, HYDRO

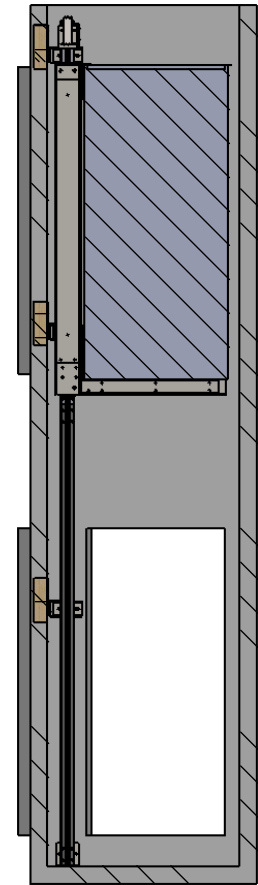
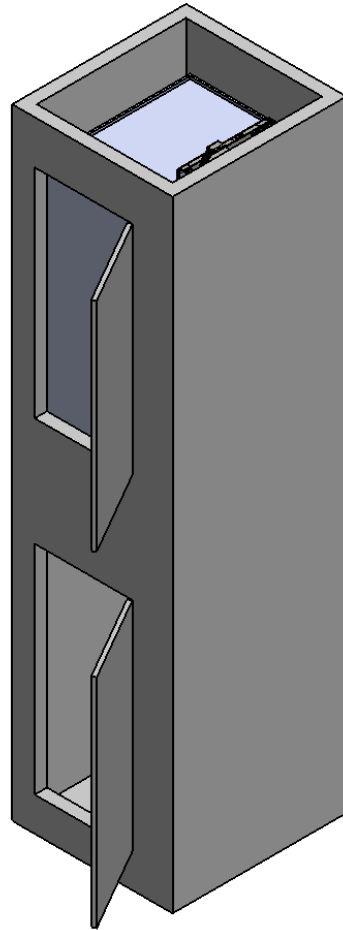
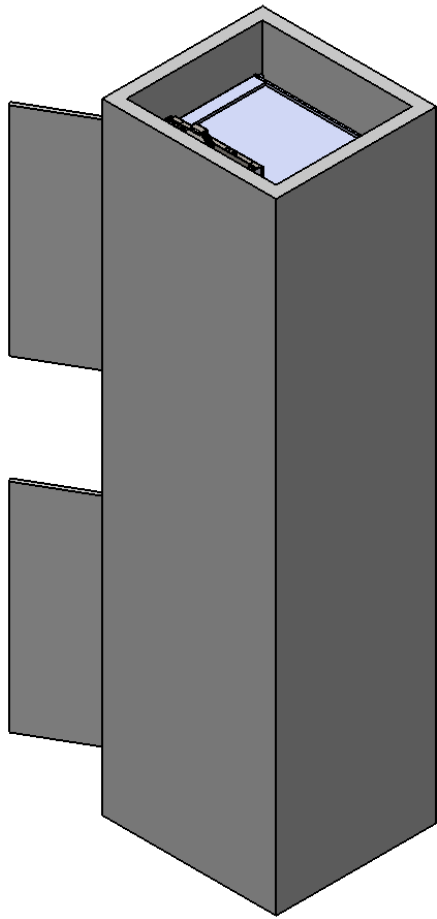

SIZE **A**  **Nationwide Lifts**  
America's *leader* in home elevators.

PART NO.  
**36 X 48, 1R**  
SHEET 3 OF 3  
DESCRIPTION:  
SWING DOORS, HYDRO